





安裝說明

Mounting instructions

整體式電子便座

Integrated shower toilet

	重要说明	ZH-TW	3
	Important information	EN	6
	安裝, Mounting		9

ZH-TW

1 關於本文件

本產品的所有文件以及詳細介紹均可線上獲取：

> 訪問 qr.duravit.com 或 www.duravit.com 查看線上文檔，並在搜索框中輸入產品編號。

2 安全

2.1 文件用途

本手冊是 Duravit 產品的組成部分。如不遵循其中的規定，可能會導致人身傷害、產品損壞和/或財產損失。

> 請閱讀並遵照手冊中的要求。

> 妥善保管本文件，並將其交給下一任使用者。

我司保留對所示產品進行技術改進和外觀修改的權利。

2.2 安裝人員及資質

僅可由衛生設備安裝技師實施安裝工作。

- 衛生設備安裝技師是指經過相關技術培訓、具備專業知識和經驗的人員，他們能夠識別並避免在衛生設備安裝過程中可能出現的危險和風險。
- 衛生設備安裝技師能夠選擇和使用適當的防護裝備。
- 衛生設備安裝技師瞭解並遵守當地供能供水企業的安裝規定和國家特定標準。

僅允許由專業電工實施電氣安裝工作。

- 專業電工是指經過相關技術培訓、具備專業知識和經驗的人員，他們能夠識別並避免電力可能產生的危險和風險。
- 專業電工能夠選擇和使用適當的防護裝備。
- 專業電工瞭解並遵守當地供能供水企業的安裝規定和國家特定標準。

2.3 電氣安全

2.3.1 電擊可導致生命危險

如與電接觸，會導致致命的電擊。

2.3.2 一般注意事項

- > 僅可將本產品連接至指定電源。
- > 產品必須正確接地。只有在接地正確的情況下才可使用本產品。
- > 在安裝前將電氣元件與電源斷開。
- > 避免意外接通供電。
- > 檢查所有元件是否無電壓。
- > 切勿用濕手觸摸電源線。
- > 如果電源線損壞，為了避免危險，必須由製造商、其維修部或類似部門的專業人員更換。
- > 禁止拆卸單個組件。

2.3.3 鋪設供電線

請鋪設連接單獨供電回路的固定供電線。

- > 注意電氣連接的位置。
- > 至少預留 500 mm (19 $\frac{1}{8}$ ") 供電線。
- > 確認接地線比相線和零線長 10 mm ($\frac{3}{8}$ ")。
- > 根據當地標準和規定以及銘牌上的連接負載值選擇供電線的橫截面積：1–2.5 mm² (17–14 AWG)。

2.3.4 安裝斷路器

安裝電氣隔離設備時必須保證接線牢固，並符合一般適用的規定。此外，這些設備必須具有過電壓等級 III 條件下的全極觸點斷開裝置。

2.3.5 安裝剩餘電流裝置 (RCD)

本產品未自帶剩餘電流裝置。必須通過一個漏電電流最大為 30 mA 的漏電斷路器 (RCD) 為其供電。

2.3.6 避免冷凝

- > 切勿將產品安裝在過於潮濕的房間內。確保通風良好，以防止電氣元件上出現冷凝。
- > 如果產品從低溫處移到暖和的地方，請先將其關閉幾個小時，以避免可能出現的冷凝。

2.4 衛生

2.4.1 髒水、污水或長期積水對健康的損害

使用髒水、污水或長期積水進行清洗可能會危害健康。

- > 本產品僅可使用自來水管道的冷飲用水。
- > 請勿連接廢水、髒水、工業用水、海水或其他未經處理和僅半處理的水。
- > 請使用隨產品附帶的新供水水管，禁止使用舊供水水管。
- > 如果產品會有兩周或更長時間不使用，請排空產品中的水並關閉產品（假期模式）。

2.5 避免產品損壞

2.5.1 一般注意事項

- > 請僅使用安裝套件中的零配件，以防發生故障。
- > 請僅使用 Duravit 推薦的配件。
- > 不可使用膠黏劑為固定方式，因膠黏劑不視為可靠的固定方式。

2.5.2 冷凍水造成的損壞

- > 請勿在有霜凍風險的房間內安裝和使用本產品。室內溫度不得低於 4 ° C (39 ° F)。



2.5.3 鈣化造成的損壞

在硬水質地區，可能會出現水垢沉積。水垢會影響本產品的性能。

- > 請檢查您所在地區的水質。如果水的硬度 $\geq 14^\circ \text{dH}$ (2.5 mmol/l)，Duravit 建議安裝軟水裝置。

3 安裝現場要求

按規定進行預先安裝。

- > 登錄 qr.duravit.com 或 www.duravit.com 打開預先安裝資料頁。
- > 確保有足夠的地面空間來安裝本產品，並且不會影響開關浴室門。
- > 確保窗框、架子和浴室傢俱不會妨礙坐便器蓋子的開合。

4 圖紙和計畫

4.1 水電連接

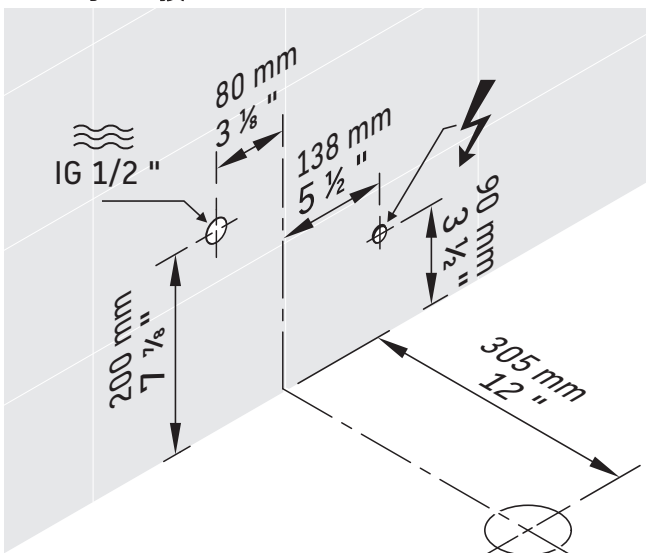

- > 確保在指定區域安裝供水介面和排水介面。
- > 確保在指定區域安裝電源介面。

5 技術資料

電氣連接	
額定電壓	110 V, 60 Hz
額定功率	1080 W
斷路器	$I_N = 16 \text{ A}$
RCD	$I_N = 30 \text{ mA}$
防護類型	IPX4
防護等級	I
電纜規格	供電線的橫截面 1 – 2.5 mm ² (17 – 14 AWG)

水管連接	
冷水	DN 15 (1/2")
水壓	0.07 – 0.75 MPa (10 – 109 psi)
水硬度	最大 2.4 mmol/l (240 ppm)

6 安裝說明

1 檢查產品

- > 檢查產品是否有損壞。

2 定位安裝支架

- > 定位安裝支架。
- > 請檢查電源線的長度和位置。電源線至少需 500 mm (19 3/8") 長。
- > 請確保排水口和水管的位置與技術圖紙和安裝支架一致。
- > 請確保安裝支架的中心位於排水口的中心。

6 密封鑽孔

- > 使用密封材料密封鑽孔。

14 準備進水口適配器

- > 用螺紋密封劑密封進水口適配器。

19 沖洗管道

提示

管道中的殘留物會引發故障

- > 打開主供水閥。
- > 打開截止閥。
- > 根據現行標準沖洗管道並收集水。
- > 關閉供水用的截止閥。



21 連接水管

提示

破損的軟管會引發故障

> 請使用隨產品附帶的新供水水管，禁止使用舊供水水管。

25 連接電線

⚠ 警告

電擊可導致生命危險

如與電接觸，會導致致命的電擊。

> 閱讀並遵照本手冊安全章節中的資訊。

> 從電線上去除大約 10 mm (3/8") 長的絕緣層。

> 將這三根線連接到端子排上。注意區分 N 線（零線）與 L 線（火線）和接地線。

> 確保接地線比 L 線（火線）和 N 線（零線）長 10 mm (3/8")。

28 檢查密閉性

> 檢查密閉性。

31 拆除安裝輔助工具

> 請確保供水管和電源線整理整齊並隱藏放置在陶瓷後面。

> 抬起產品。

> 拆除安裝輔助工具。

32 定位產品

> 謹慎放置產品並確認定位。

> 確保 L 型安裝塊和底部法蘭在定位時未損壞。

> 確保軟管沒有扭曲或扭結。

44 + 53 產品測試

> 檢查產品是否正常工作。

> 請遵循操作手冊。

⚠ 注意

磷水、污水或長期積水對健康的損害

使用磷水、污水或長期積水進行清洗可能會危害健康。

> 如果產品會有兩周或更長時間不使用，請排空產品中的水並關閉產品（假期模式）。



EN

1 About this document

All documents related to this product and further information are available online:

- > Access the online documents at qr.duravit.com or www.duravit.com and enter the article code in the search field.

2 Safety

2.1 Purpose of the document

The instructions are part of the Duravit product. Failure to follow the instructions may result in personal injury, product damage and/or property damage.

- > Read and follow the instructions.
- > Keep this document and pass it on to subsequent users.

We reserve the right to make technical improvements and visual changes to the products illustrated.

2.2 Target readership and qualifications

All work associated with the installation may only be undertaken by plumbers.

- Plumbers are persons with the appropriate technical training, knowledge and experience so that they can recognise and avoid dangers and risks that may arise during the installation in the sanitary area.
- Plumbers are qualified to select and use suitable protective equipment.
- Plumbers are familiar with and observe the installation regulations of local utility companies and country-specific standards.

The electrical installation may only be carried out by an electrician.

- Electricians are persons with the appropriate technical training, knowledge and experience so that they can recognise and avoid dangers and risks that may be caused by the electricity.
- Electricians are qualified to select and use suitable protective equipment.
- Electricians are familiar with and observe the installation regulations of local utility companies and country-specific standards.

2.3 Electrical safety

2.3.1 Risk of fatal injury caused by electric shock

Contact with electricity can lead to a fatal electric shock.

2.3.2 General precautions

- > Connect the product only to the specified power supply.
- > The product must be earthed. Do NOT operate the product without proper grounding.
- > Disconnect electrical components from the power supply before the installation.
- > Prevent the power supply from being switched on accidentally.
- > Check that all components are de-energised.
- > NEVER touch the power supply cable with wet hands.
- > If the power supply cable on this product is damaged, it must be replaced by the manufacturer, the customer service agent or similarly qualified persons in order to avoid a hazard.
- > Do NOT remove individual components.

2.3.3 Laying a supply line

Lay a permanent power supply line which must be on a separate circuit.

- > Observe the position of the electrical connection.
- > Leave at least 500 mm (19 3/8") of supply line exposed.
- > Ensure that the protective earthing conductor is 10 mm (3/8") longer than the L and N conductors.
- > Check the rating label for the rated power and choose the supply line cross section according to local standards and regulations: 1 – 2.5 mm² (17 – 14 AWG).

2.3.4 Installing a circuit breaker

Means for disconnection must be incorporated in the fixed wiring in accordance with the wiring rules and having a contact separation in all poles that provide full disconnection under overvoltage category III conditions.

2.3.5 Install residual current device (RCD)

The product itself does not have electrical leakage protection function. The product must be supplied through a residual current device (RCD) not exceeding max. 30 mA.

2.3.6 Avoid condensation

- > Do NOT install the product in a room exposed to excessive moisture. Ensure sufficient ventilation to avoid condensation in electric components.
- > When the product is brought from a cold location to a warm one, leave the unit switched off for a few hours to avoid condensation.



2.4 Hygiene

2.4.1 Damage to health caused by dirty, polluted or long standing water

Operating the shower functions with dirty, polluted or long standing water can cause damage to health.

- > Supply the product with cold drinking water from the main water system.
- > Do NOT connect any waste water, grey water, industrial water, sea water or other untreated or semi-treated water.
- > Only use the water supply hoses provided with the product. Do NOT reuse old hoses.
- > If the product is NOT to be used for two weeks or more, empty the product and switch it off (holiday mode).

2.5 Avoid product damage

2.5.1 General precautions

- > Only use the parts in the installation kit to avoid malfunctions.
- > Only use attachments recommended by Duravit.
- > Do NOT use adhesive to fixate.

2.5.2 Damage through freezing water

- > Do NOT install and operate the product in rooms where there is a danger of frost. The room temperature must not be less than 4 °C (39 °F).

2.5.3 Damage due to limescale build-up

Limescale can build-up in regions with hard water. Limescale can impair the performance of the product.

- > Check the water quality in the region. Duravit recommends the installation of a water softener with water hardness ≥ 14 °dH (2.5 mmol/l).

3 Requirements at the installation location

The pre-installation is carried out properly.

- > Access the pre-installation data sheet at qr.duravit.com or www.duravit.com.
- > Ensure that there is enough floor space to install the toilet and that bathroom door will open and close without obstruction.
- > Ensure that the lid will open and close without obstruction against window frames, shelves and other bathroom furniture.

4 Drawings and plans

4.1 Water and power connections

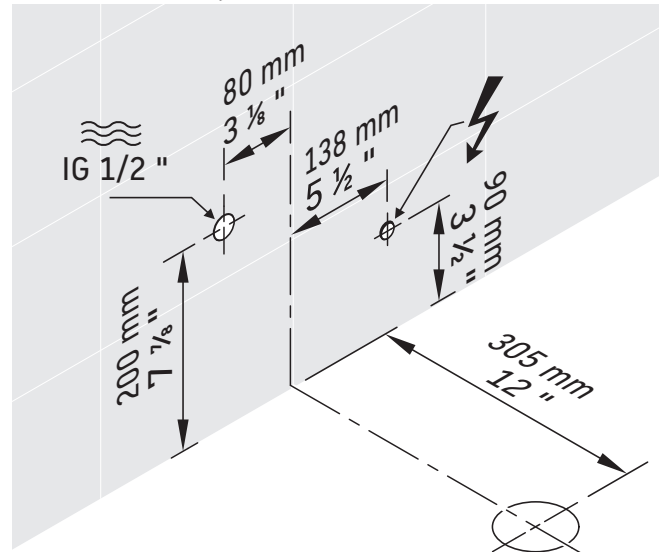

- > Ensure that the water connection and drain are installed in the specified areas.
- > Ensure that the electrical connection is installed in the specified areas.

5 Technical data

Electrical connection	
Rated voltage	110 V, 60 Hz
Rated power	1080 W
Circuit breaker	$I_N = 16$ A
RCD	$I_N = 30$ mA
Protection degree	IPX4
Protection class	I
Cable specification	Supply line cross section 1 – 2.5 mm ² (17 – 14 AWG)

Water connection	
Cold water	DN 15 (1/2")
Water pressure	0.07 – 0.75 MPa (10 – 109 psi)
Water hardness	Max. 2.4 mmol/l (240 ppm)



6 Mounting instructions

1 Inspecting the product

- > Inspect the product for damages.

2 Positioning the mounting template

- > Position the mounting template.
- > Check the length and position of the power cord. The power cord must be at least 500 mm (19 $\frac{3}{8}$ ") long.
- > Ensure that the location of the drain and water pipe correspond to the technical drawing and the mounting template.
- > Ensure the mounting template is centered at the middle of the drain.

6 Sealing drill holes

- > Seal the drill holes with sealing material.

14 Preparing the water inlet adapter

- > Seal the water inlet adapter with a threaded seal.

19 Flushing the pipes

NOTE

Malfunctions caused by dirty pipes

- > Open the main valve for the water supply.
- > Open the stop valve.
- > Flush the pipes according to the local standards and collect the water.
- > Close the stop valve for the water supply.

21 Connecting the water

NOTE

Malfunctions caused by defective hoses

- > Only use the water supply hoses provided with the product. Do NOT reuse old hoses.

25 Connecting the wires

WARNING

Risk of fatal injury caused by electric shock

Contact with electricity can lead to a fatal electric shock.

- > Read and observe the information given in the safety chapter of this manual.
- > Remove approximately 10 mm ($\frac{3}{8}$ ") of insulation from the wires.
- > Connect the three wires to the terminal block. Observe the L, N and PE conductors.
- > Ensure that the protective earthing conductor is 10 mm ($\frac{3}{8}$ ") longer than the L and N conductors.

28 Checking for leaks

- > Check for leaks.

31 Removing installation aids

- > Ensure that the water connection line and the power cord are properly tucked away behind the ceramic.
- > Lift the product.
- > Remove the installation aids.

32 Positioning the product

- > Carefully lower and position the product.
- > Ensure that the L-shaped mounting blocks and the bottom flange are NOT damaged while positioning the product.
- > Ensure that the hose is not bent or kinked.

44 + 53 Testing the product

- > Check if the product works properly.
- > Observe the user manual.

CAUTION

Damage to health caused by dirty, polluted or long standing water

Operating the shower functions with dirty, polluted or long standing water can cause damage to health.

- > If the product is NOT to be used for two weeks or more, empty the product and switch it off (holiday mode).

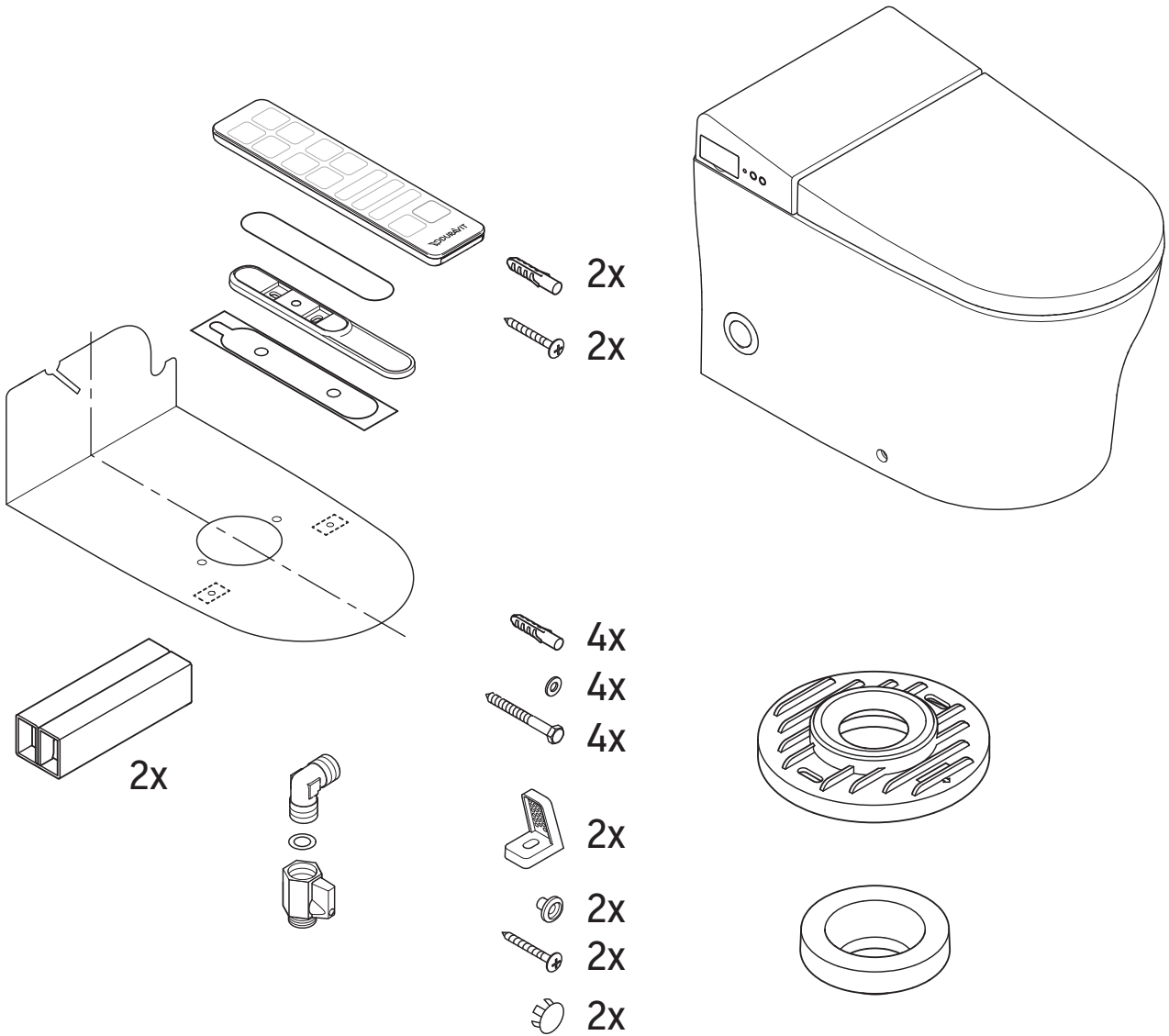

#622000 01 1 00 1301

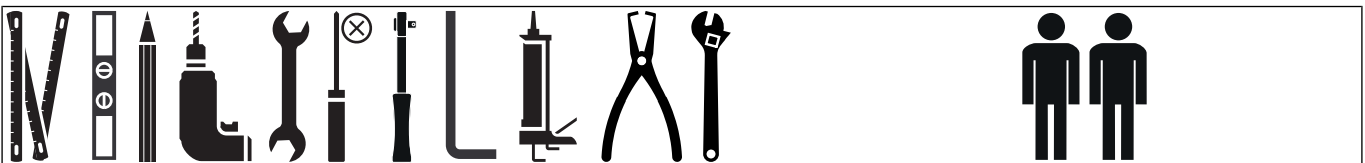



1 ▶ i

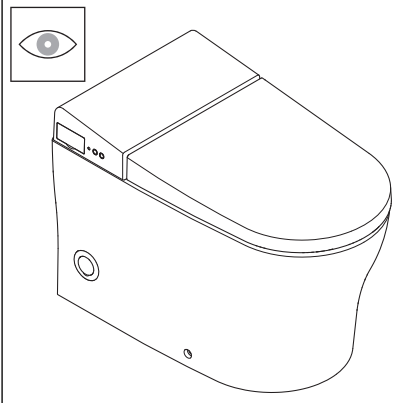

5

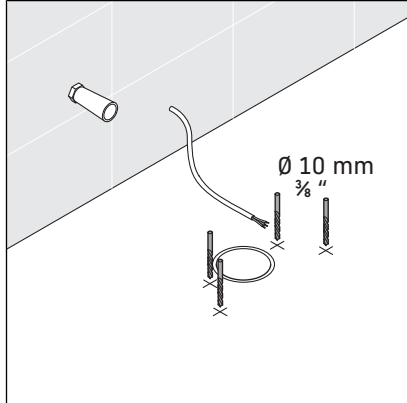

9

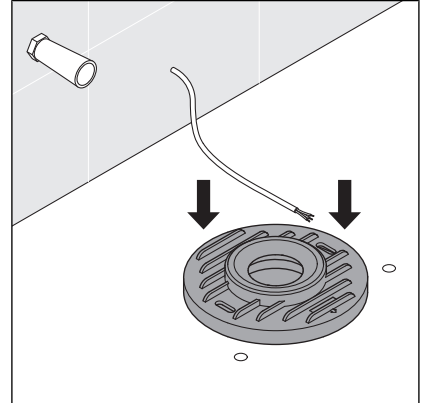

2 ▶ i

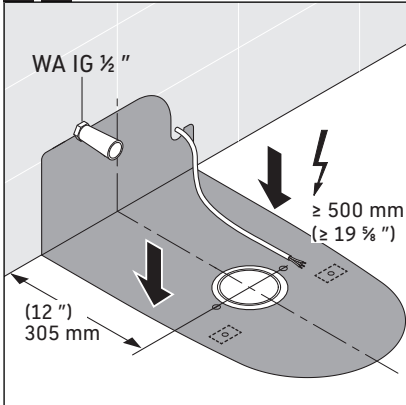

6 ▶ i

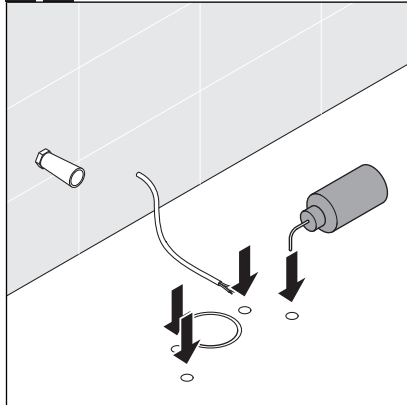

10

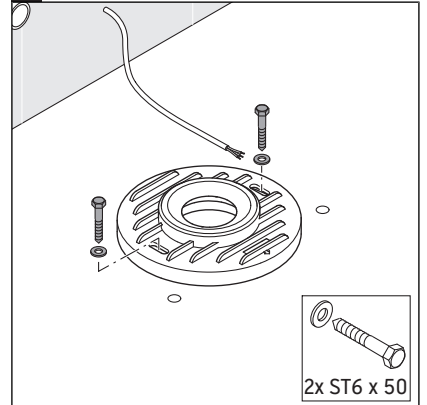

3

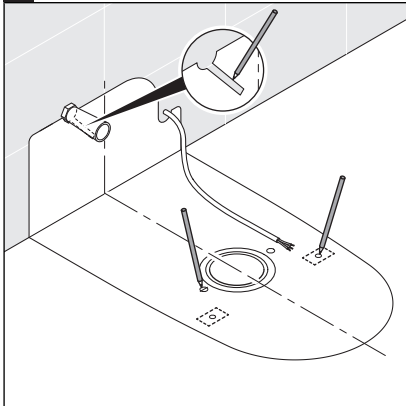

7

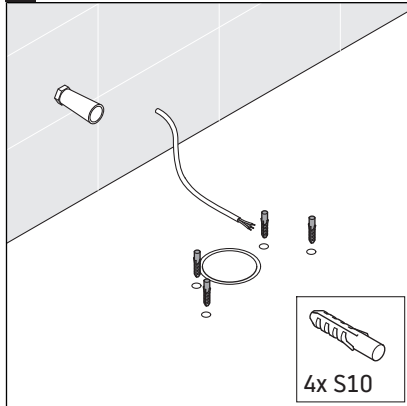

11

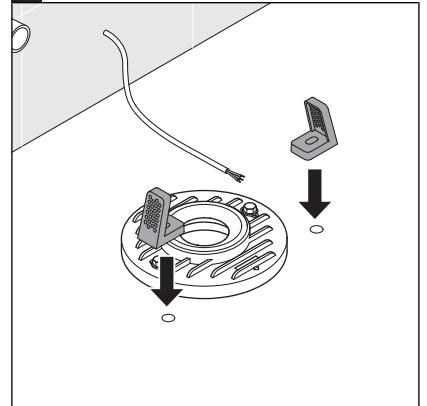

4

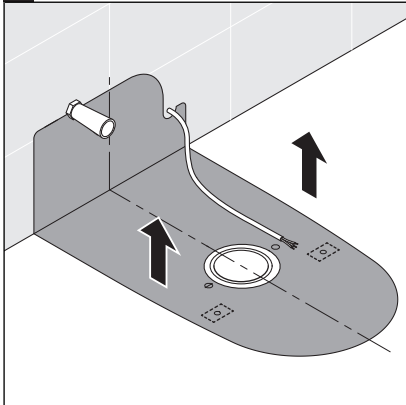

8

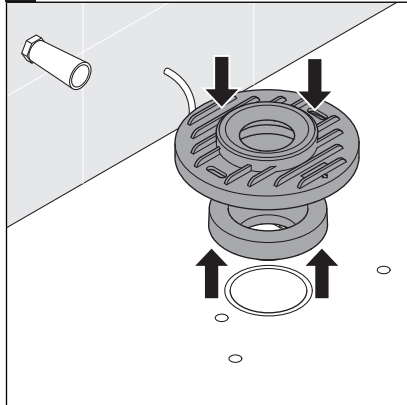

12

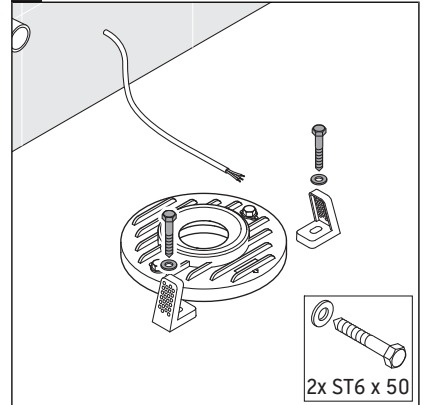

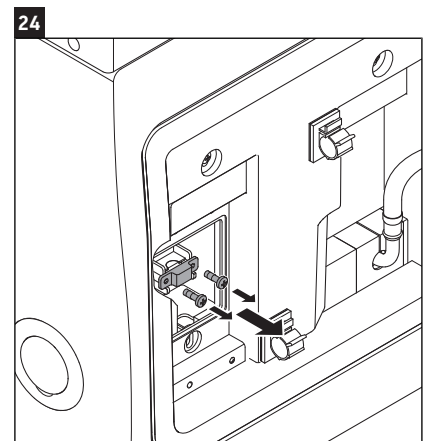
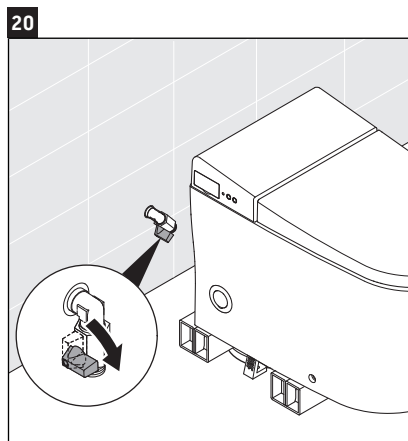
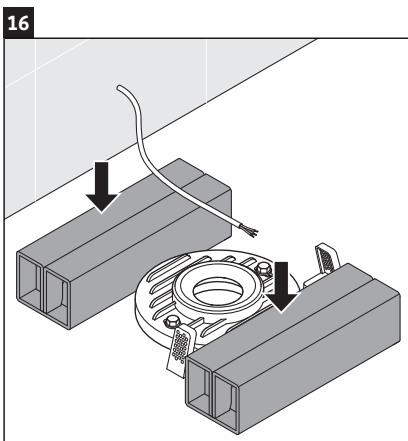
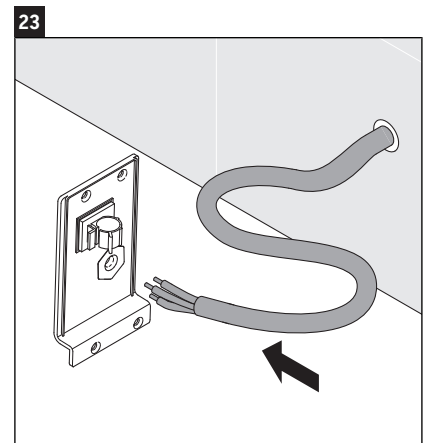
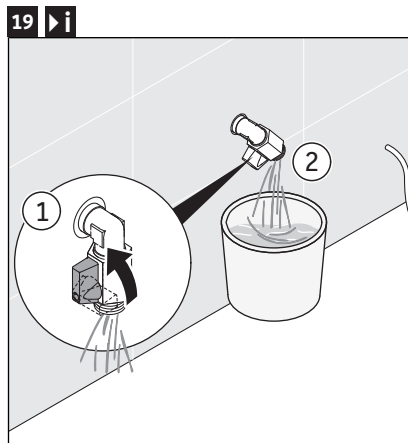
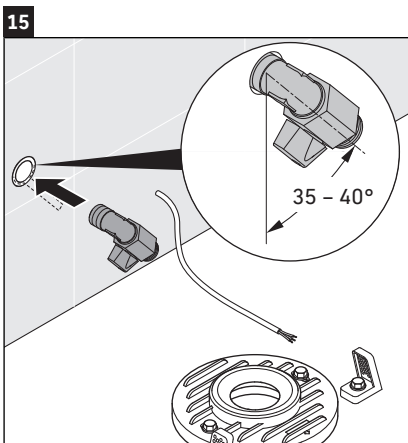
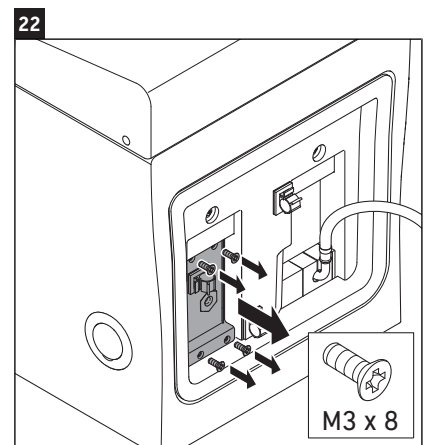
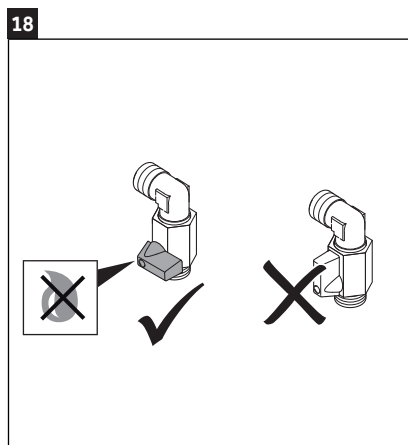
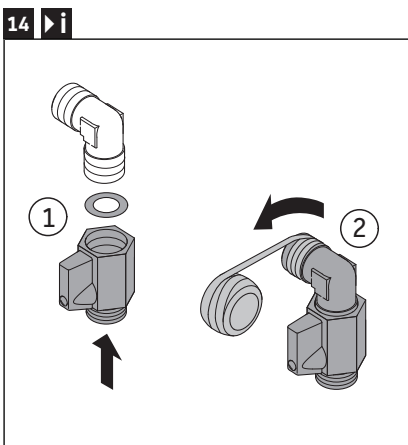
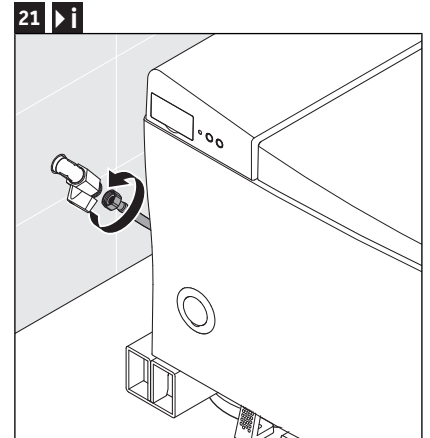
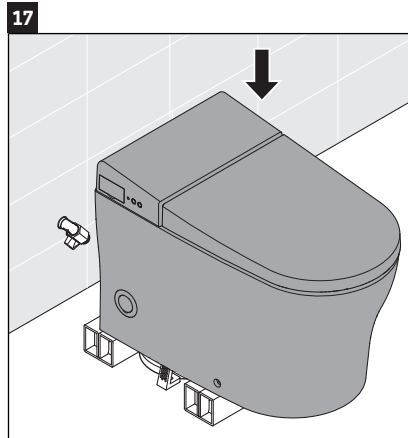
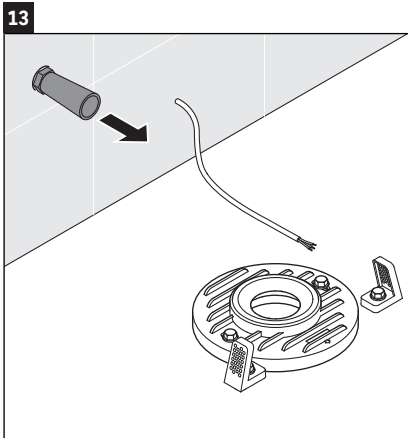

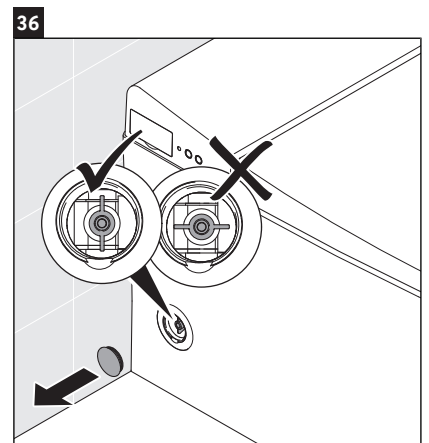
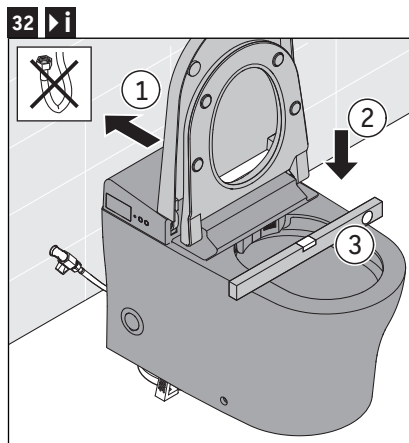
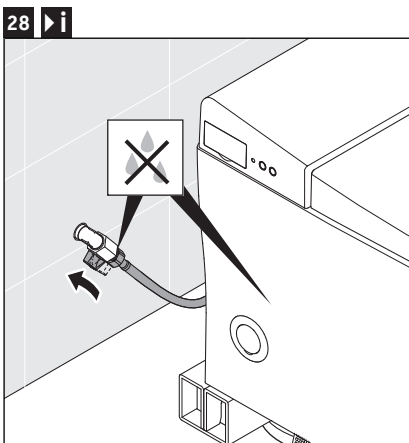
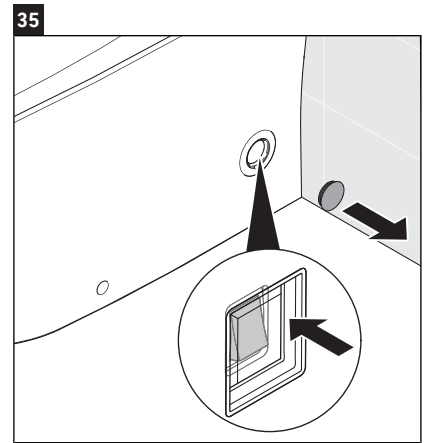
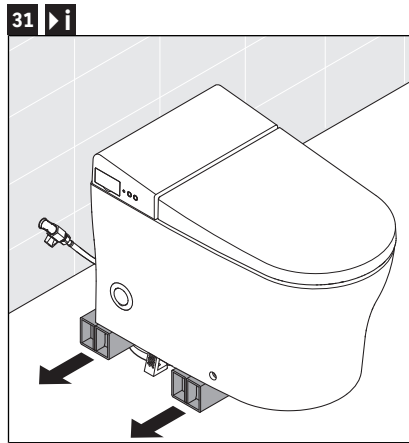
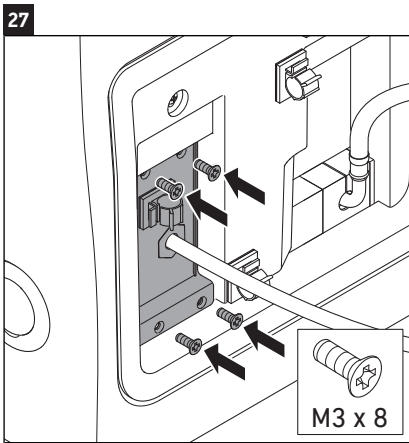
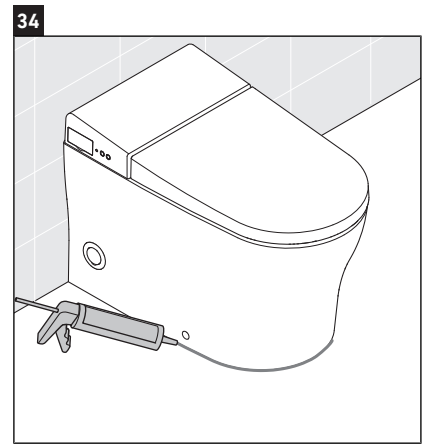
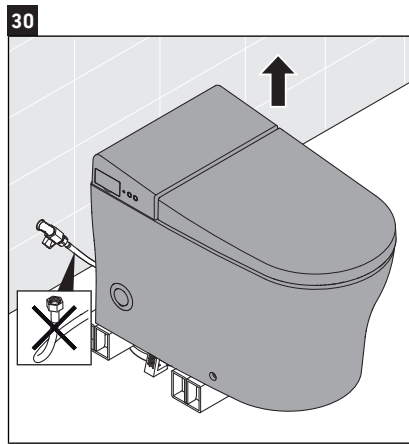
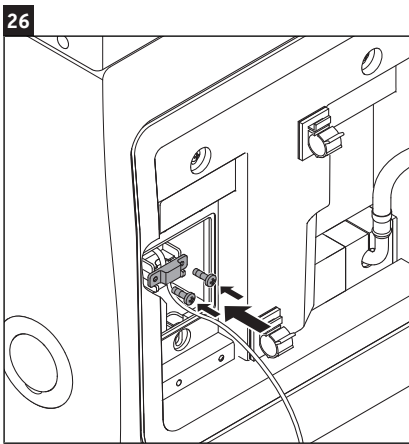
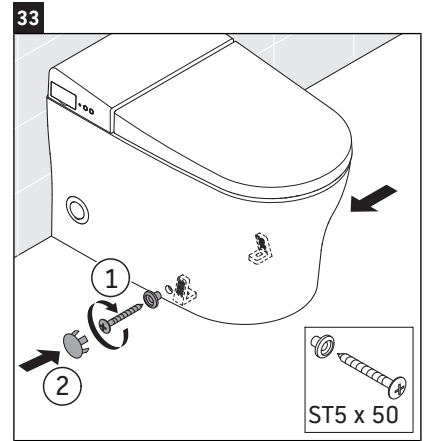
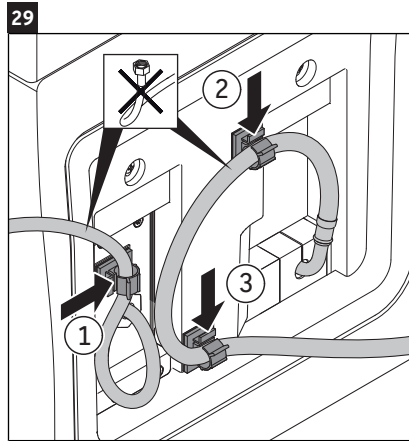
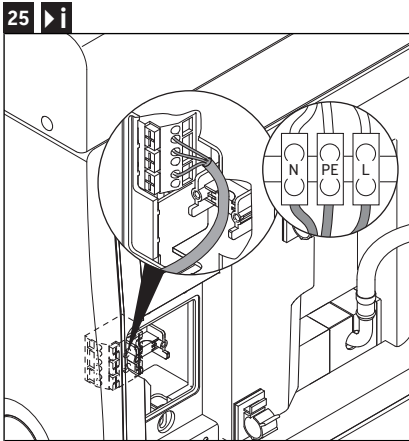

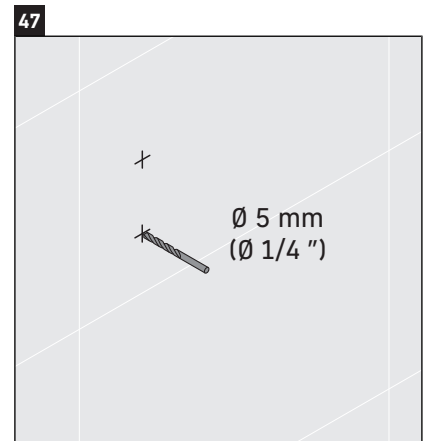
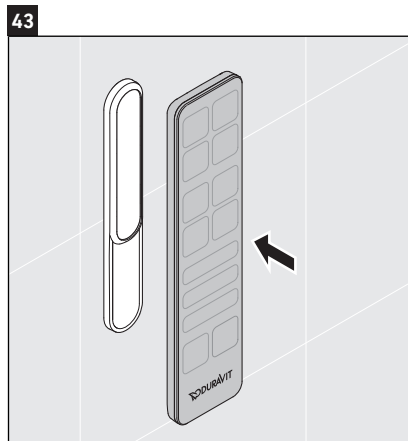
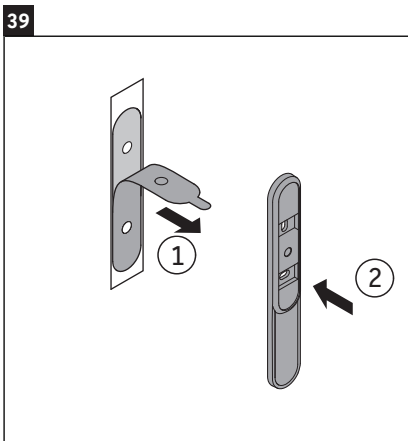
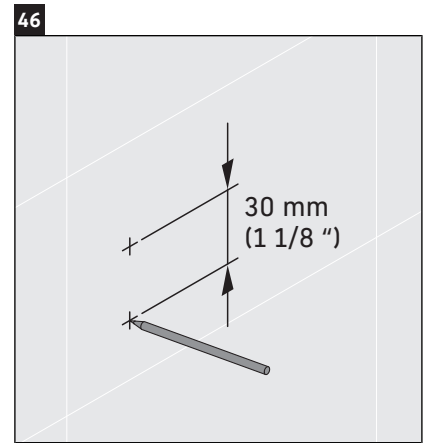
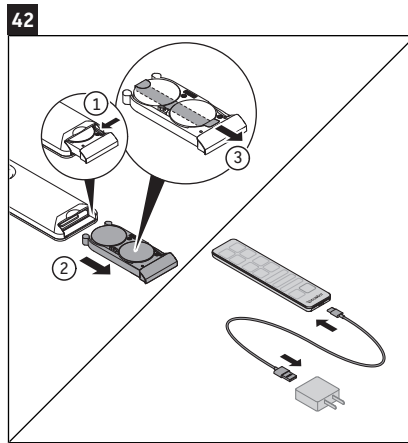
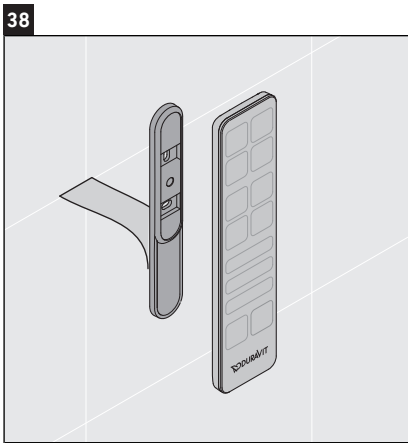
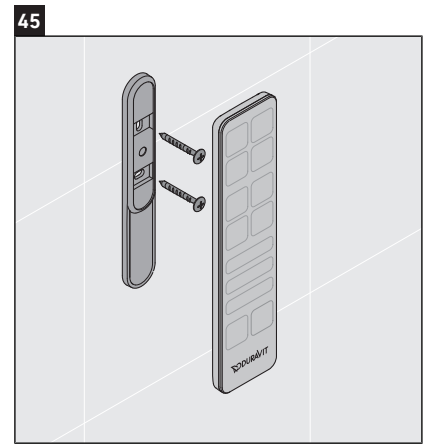
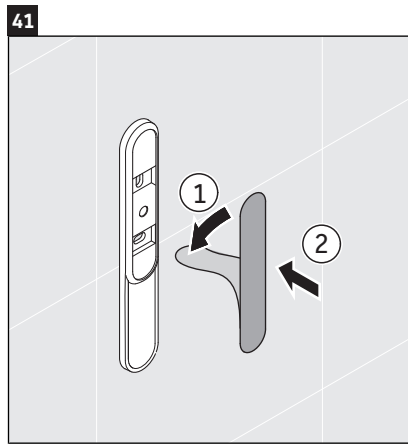
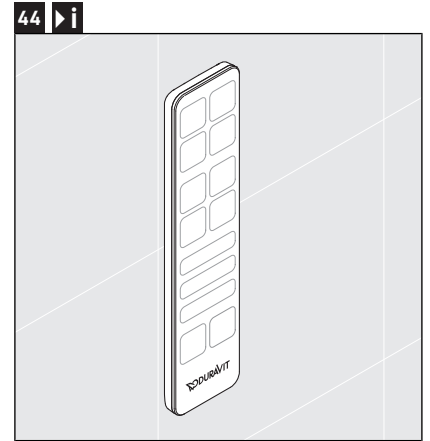
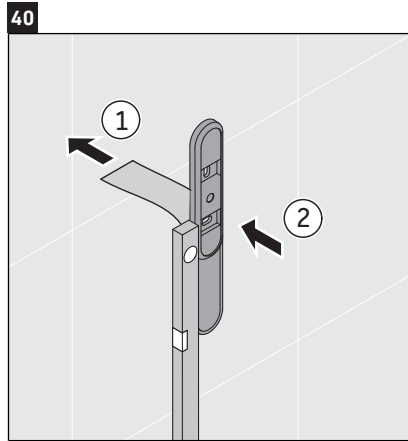
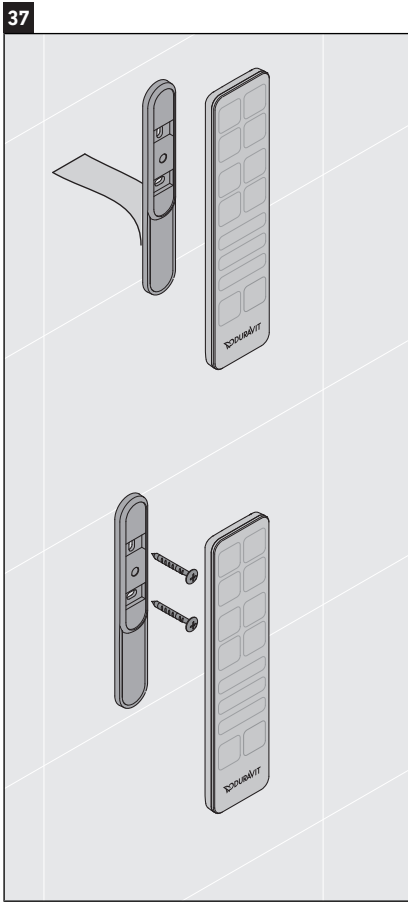



48

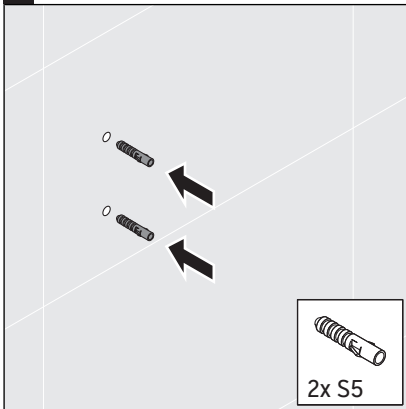

52

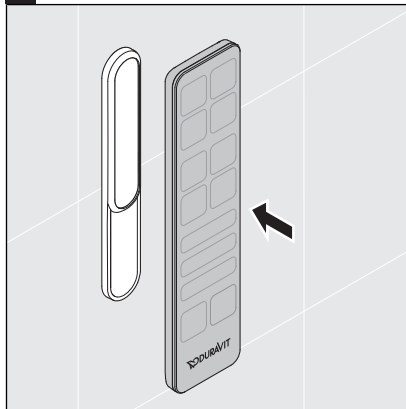

49

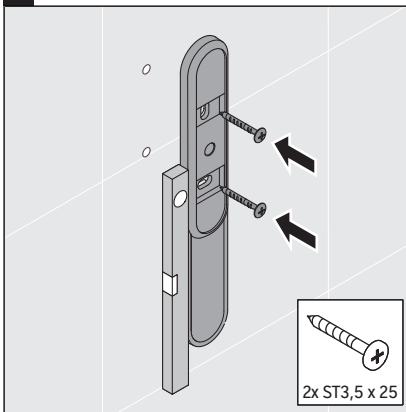

53 ▶ i

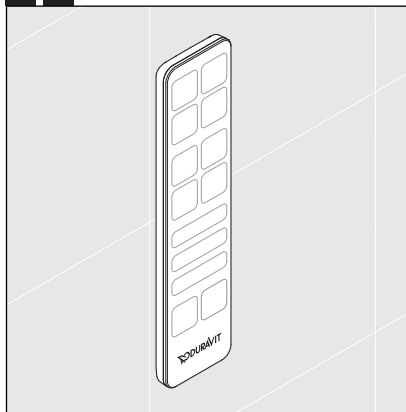

50

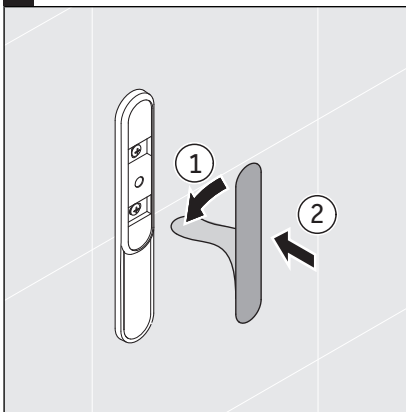

51

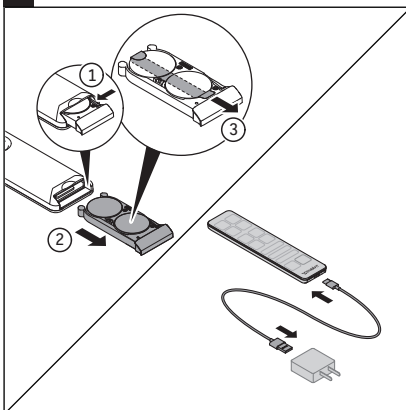

Duravit AG
P.O. Box 240
Werderstr. 36
78132 Hornberg
Germany
Phone +49 78 33 70 0
Fax +49 78 33 70 289
info@duravit.com
www.duravit.com

